

Lessons 5 and 6

Plan an oral presentation

and

Write a formal explanation text

Success Criteria

1. Compare instructional and explanatory texts.
2. Plan an oral presentation to explain an invention in Dragon's Den style.
3. Use notes as prompts.
4. Write a formal explanation text which aims to explain and persuade.
5. Use commas and brackets to indicate parenthesis.

Session 1

Plan an oral presentation.

Create a side-by-side list of the features of instructions and explanations (in your books) picking out similarities and differences.

Instructions

tells how to **do** or **make** something.

- a **title** telling what's to be achieved
- if relevant, **list(s)** of ingredients/equipment needed layout which clearly shows the sequence of steps

What else can you remember?

Explanations

tells **how** or **why** a process happens (or how something works).

- a **title** telling what's to be explained
- introduction, providing any necessary background
- clear layout (e.g. sections, paragraphs) which helps show the stages in the process.

What else can you remember?

Create a side-by-side list of the features of instructions and explanations (in your books) picking out similarities and differences.

Instructions

tells how to **do** or **make** something.

- a **title** telling what's to be achieved
- if relevant, **list(s)** of ingredients/equipment needed layout which clearly shows the sequence of steps
- perhaps labelled **pictures** or **diagrams**
- especially a picture of the finished product, so the reader knows what to aim for
- perhaps other organisational devices (e.g. **boxes** for additional information, **bullet points**, warning **symbols**) to aid clarity.

Explanations

tells **how** or **why** a process happens (or how something works).

- a **title** telling what's to be explained
- introduction, providing any necessary background
- clear layout (e.g. sections, paragraphs) which helps show the stages in the process
- each paragraph starts with a topic sentence (A topic sentence sums up what the paragraph is about.)
- maybe labelled **picture(s)** or **diagram(s)**
- organisational devices to aid clarity (e.g. **bullet points**, subheadings)
- closing sentence, to round off the report.

- New technology often demands instructions for use and explanations of how they work.
- Look at the Baby Cage pictures on the next few pages and discuss.



The Baby Cage
(London 1930s)





These incredible pictures taken in the 1930s show babies suspended high up in flats from their parents' window.

Incredibly, the then East Poplar borough council in London proposed to fix the cages to the outside of some of their buildings so that babies could benefit from fresh air and sunshine.

The idea behind the cages was **patented** in America in 1922 (by Emma Read, from Washington) as a means to help parents living in cities who didn't have much space. The benefits were said to be fresh air for the child, room to play with toys and another place for children to sleep.

The cages in the patent were also designed with a slanted, overlapping roof which was said to protect babies from snow or rain.

What does **patented** mean?

If you create an invention, a patent is to say that it is your idea and it belongs to you.

It gives you full ownership. You can charge someone to use your invention.

Task 1

- Today you will be planning explanations of a genuine patented product – The Baby cage.

Produce and perform *Dragon's Den* style presentations of wacky inventions

- You will have a patent design – The baby cage.

Plan a **short** presentation (pitch), explaining how the invention works.

- Remember to use explanation features (referring to slide at the beginning)

- **Plenary:** Hold Dragon's Den style pitching sessions with someone at home
- What makes a successful presentation?
- Do they want to buy your product?!

Session 2

Write a formal explanation text which aims to explain and persuade

TASK

TASK: Look at the patent designs on the next few pages. These are actual inventions that people tried to make!!

Pick **ONE** and write an explanation text, explaining how the invention works.

REMEMBER:

- Use formal, persuasive tone.
- Use features of explanation texts for reference.

Have a look at my example after all the pictures!

Crazy Inventions Registered with US Patent Office (1)

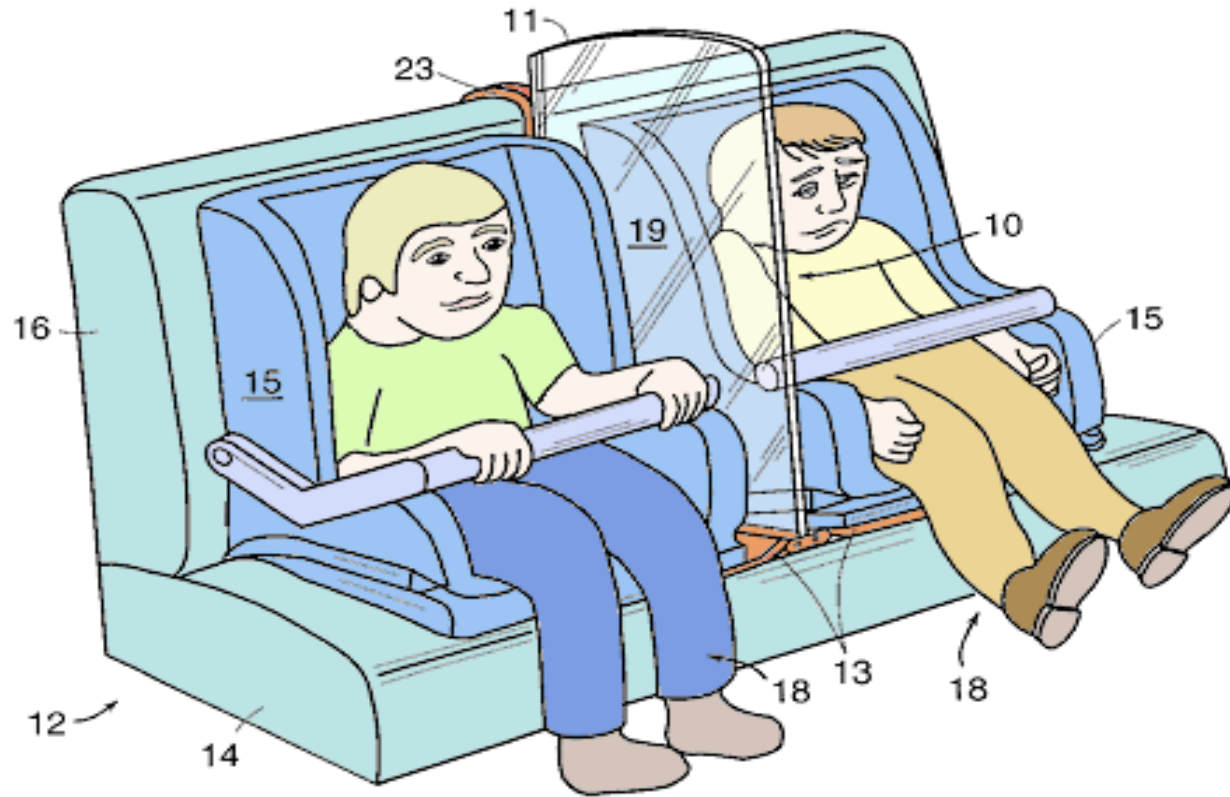

The Squabble Shield

Crazy Inventions Registered with US Patent Office (2)

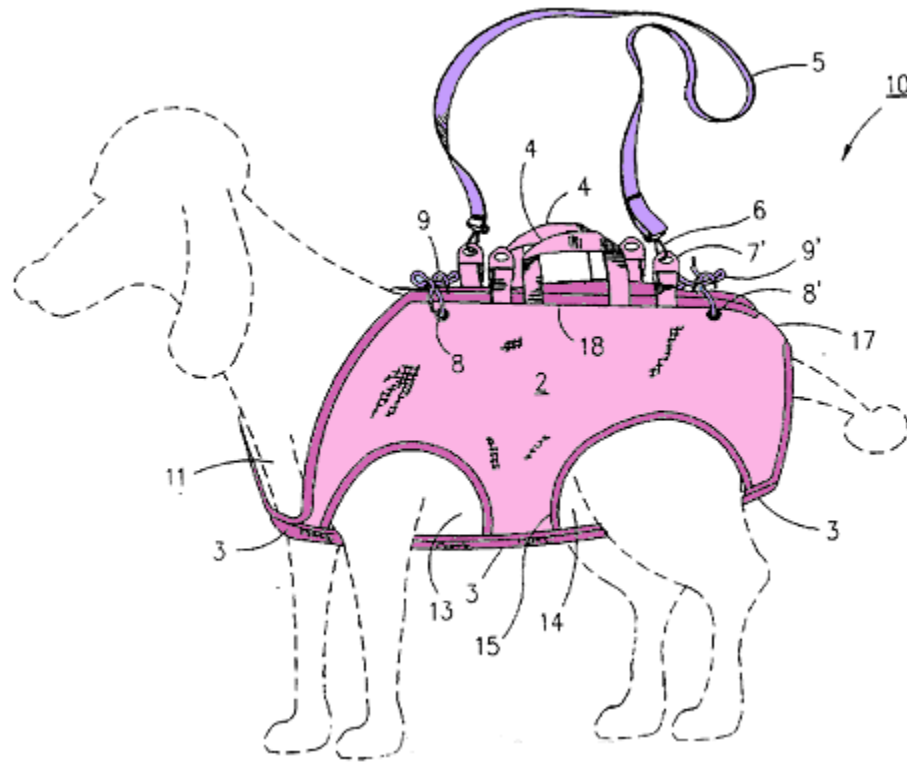

Doggie Luggage

Crazy Inventions Registered with US Patent Office (3)

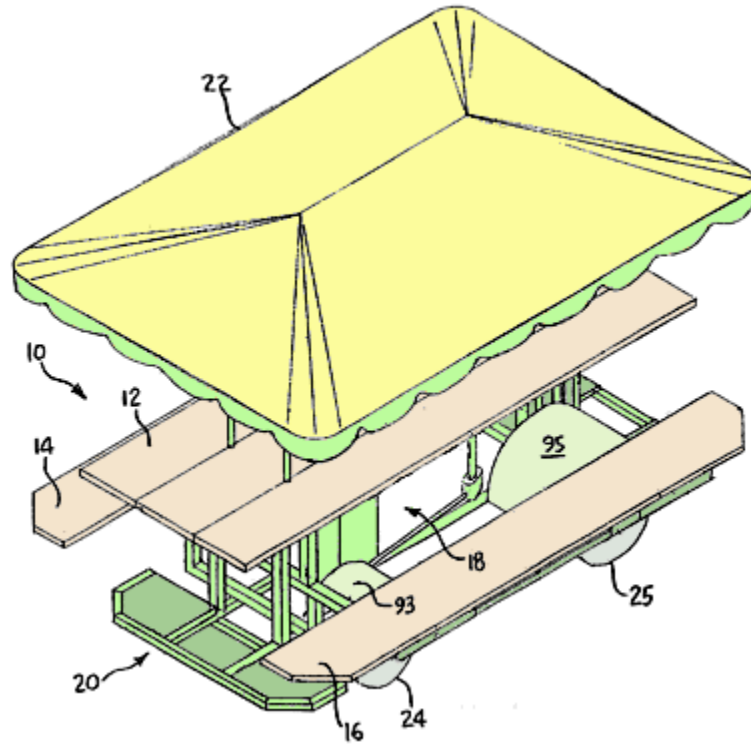

**Motorised Picnic
Table**

Crazy Inventions Registered with US Patent Office (4)

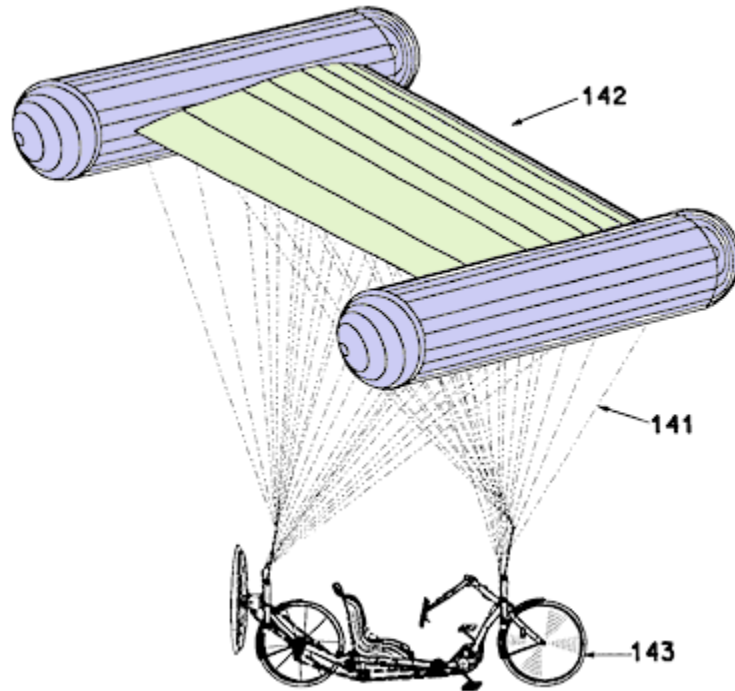

Flying Bike

Crazy Inventions Registered with US Patent Office (5)

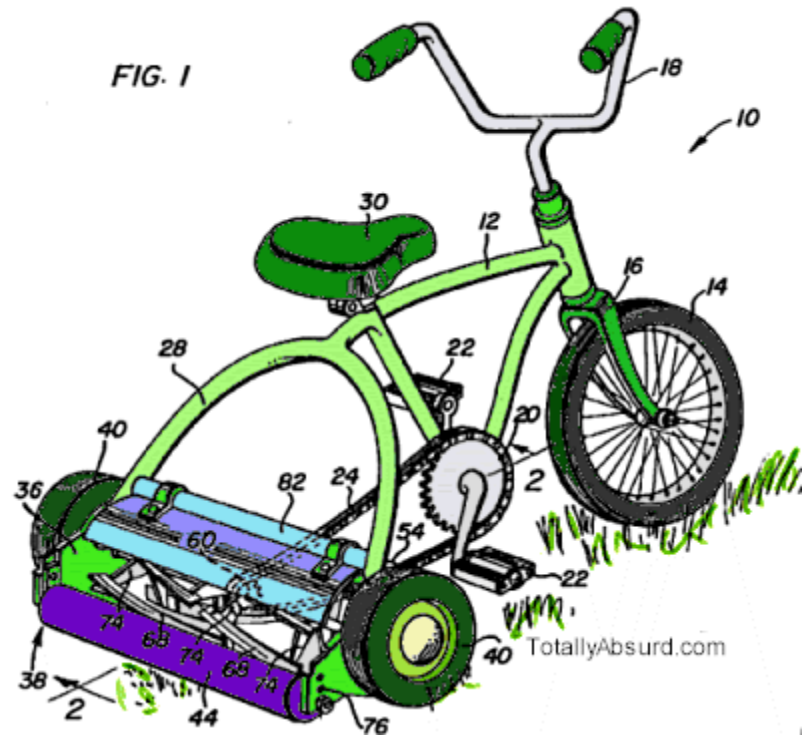

Tricycle Lawn Mower

Crazy Inventions Registered with US Patent Office (6)

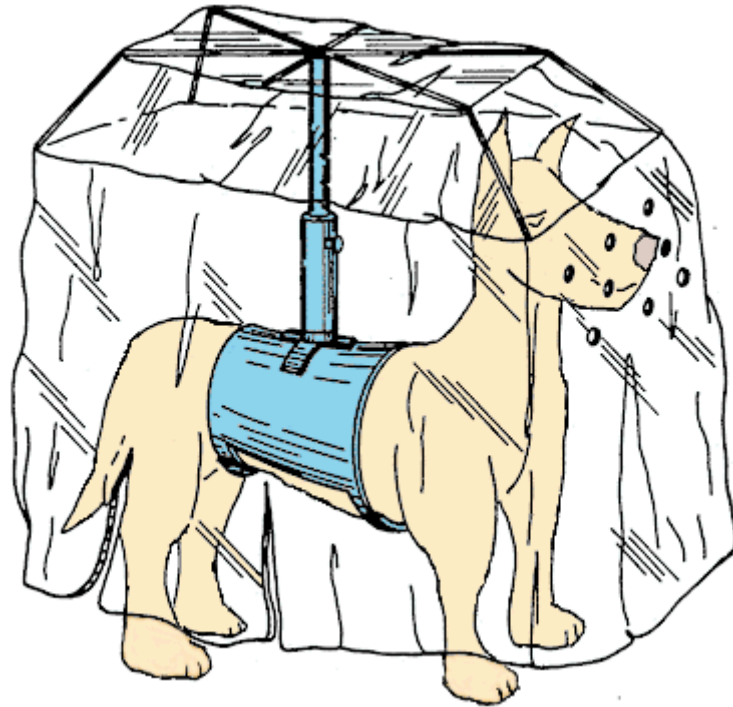

Doggie Umbrella

Here is my example for a motorised wash cloth!

Use these prompts to help you write your explanation pitch (my examples are in blue):

- Write a **title** with the name of your invention (try alliteration or onomatopoeia to draw attention)

The Wonderful Wash Cloth

- Write a **short introduction**, answering these questions: **Who? What? Where? When? Why?**

(Who will use it? What is it? Where will it be used? When will it be used? Why will someone want to use it?)

This is a time-saving, bathroom wash cloth for busy people, rushing to get ready in the morning for work and school.

- Write a **more detailed explanation** of how the product works

(Write in clear sections/stages, use organisational devices, include labelled diagrams and use explanation language)

Operating the Wonderful Wash Cloth is a quick and easy process. As soon as the power button is pressed (28) a gentle humming can be heard from the powerful motor, housed inside the unit.

Holding the unit by the easy-grip handle (30), the user waits until the indicator warning light changes from red to green (38). Then, the microfibre patented cleaning cloth will be propelled from the firing unit and simultaneously commence rotating at increasing speed, providing powerful cleaning as a result.

Now the unit is ready. As the cloth is brought in contact with the skin, it will whisk away dead skins cells and everyday grime. Therefore, it is recommended that you replace the cloth with a fresh cloth after each use. (To release, simply twist the release cylinder (20) and slide out).

When not being used, the unit can be stored in direct sunlight, in order to enable the solar panel to charge.

- End with a **neat closing sentence**

Washing will never be the same. Welcome to the washcloth of the future.

Think about:

present tense, 3rd person,
linking adverbs, causal
language, technical words

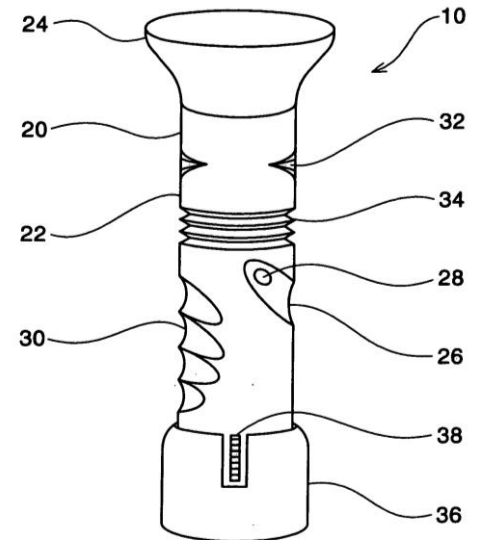

Now it's your turn.

1. Write a **title** with the name of the invention (try alliteration or onomatopoeia to draw attention)
2. Write a **short introduction**, answering these questions: **Who? What? Where? When? Why?** (Who will use it? What is it? Where will it be used? When will it be used? Why will someone want to use it?)
3. Write a **more detailed explanation** of how the product works (Write in clear sections/stages, use organisational devices, include labelled diagrams and use explanation language)
4. End with a **neat closing sentence**